

Kouga Wildernis

Rock Climbing Guide



www.easterncaperockclimbing.co.za



Legal Note: All climbing is very dangerous & always at your own risk. Nobody is forcing you to climb. You choose to climb, so choose to go home before the risks become too high. Remember even small injuries can take 6 weeks to heal. No responsibility for inaccurate or incomplete information will be accepted by the scribe. The landowner accepts no liability at all. Climbers take full responsibility for themselves at all times. Fixed protection will become unreliable, loose rock is common, solid rock becomes loose & RD writers make up most of the information, with a beer, at the computer. This RD is only a guide & is no substitute for experience, training, common sense & a touch of caution. So, you are on your own...take care!

Note from the Scribe: It took consistent effort, time, work & organization to get this guide ready for your pleasure...for free! Thus, please respect that all the information & photographs are strictly Copy Righted. You are more than welcome to print out, e-mail or link to a web page this guide in its unchanged format, with logos & all information intact.

As this is a web-based guide it can be considered a continual work in progress. It is easy to change. So please send missing details, corrections, additions & adjustments to info@easterncaperockclimbing.co.za. All information will be greatly appreciated.

Directions: From the R62 turn onto the gravel road to Onder-Kouga. Follow this road to a fork, take the RH option. Over the rugged mountain pass & cross the Kouga River. Follow the river for a few kilometers, then up a steep hairpin pass. On the level ground on top take a L where there is a signpost *Kouga Wildernis*. Follow this road down another steep pass to Kleinrivier farm. After stopping at the farmhouse to make the necessary arraignments, continue up the valley for about 1.5km to a sweet piece of green grass, that is the campsite. *Leopard Rock* stands imposingly above the campsite.

Access: Kouga Wildernis is owned by Nico & Melodie Ferreira who have embraced climbing. They must be contacted to book accommodation 042-2739903. There are no access restrictions. You would be expected to be a guest to be able to climb, but it is super remote. You would want to stay a few days.

Accommodation: The Ferreira's have a super main camp site set in a secluded valley. They also have various superb cottages houses. The new campsite at *Heuning Kranz* has sport lines in the campsite & various sport lines within 5 minutes' walk of the campsite. So, take your pick.

General: This is an awesome spot to camp, climb & hangout with your family. There is a pool, ample green grass, 100-year-old oaks for shade & a huge lapa. Totally crime free remote wilderness. Check out www.kougawildernis.co.za/ for all the details, rest day ideas & lots of pictures.

Rock: Sandstone & quartzite mix. 16 bolted routes and 99 trad routes. There is still a fair potential for new routes. The writer is saving the knowledge of these for his own pleasure.

Time & Weather: The crags close to the campsite are very sunny in summer.

Star Ratings

- ★★★ Classic route in this province
- ★★ Good route in the area
- ★ Good route at this crag
- No star Reasonable to bollocks

Abbreviations & Symbols

- 7₁₉ (T) Trad route (natural gear) & grade
- 9₂₁ Sport route (bolted) & grade
- 4₂₅ Open Project / in-progress & ± grade
- 4₂₁ Closed Project & ± grade
- 7₁₉ (S) FA was solo & grade
- ▲ Potential
- ⊖ Abseil point
- (11B&C) Number of bolts & top chains
- P / RB Piton / Removable bolt
- Afternoon Shade
- Morning Shade
- Shade all day
- Sun all day
- Dappled shade all day
- Can be climbed in wet weather

Wake up early, 5am & get up there, then come down for siesta at 11am. Climb again after 3pm. *Kos sê Bos* has shaded crags & caves, but the walk over the spur is seriously hot & must be done in the cool of the morning.



Hazards: Area is totally safe, but watch out for:

1. **Snakes**, these critters must be somewhere.
2. **Leopards**, Mr Ferreira loses sheep to leopards every year. They are there!
3. **Baboons**, stay way & never try to case them away or displace them. They are dangerous!
4. **Sun & dehydration**: climb early & late during summer. Siesta in the pool!
5. Don't mess with the **farmer**.
6. Don't make **fires** out of the campsite. This is a dry area & veld is money. (See point 1 under environmental)
7. **Quad & dirt bikes**. Ja...you go to jail if you string up a steel cable just to get some piece & quiet. These guys are more irritating than dangerous. Check if the riders are from **Uitenhage** before telling them to quieten down.

Environmental: Kouga Wildernis is unspoiled wilderness.

1. If you need to go to the toilet in the bush or at the crags, please bury your business well. Don't burn the toilet paper as this may set the veldt alight.
2. Don't scratch the walls or floor in the Bushman/San caves. It is illegal & the fine is R10 000.

History: *Kouga Wildernis* has an interesting history. There are San paintings & artifacts to be seen in the caves at *Kos sê Bos*.

Mummified San skeletons have been found on neighboring farms. Mr Ferreira's family have farmed *Kleinrivier* since the 1815. He will be happy to relate his family's history. Ask him about the leopards.

The climbing was discovered, developed & championed by Bronwyn & Vincent Egan in 2001.

Ferreira's Slab



This is the un-miss able slab just before the farmer's house. Park & walk through the lands.

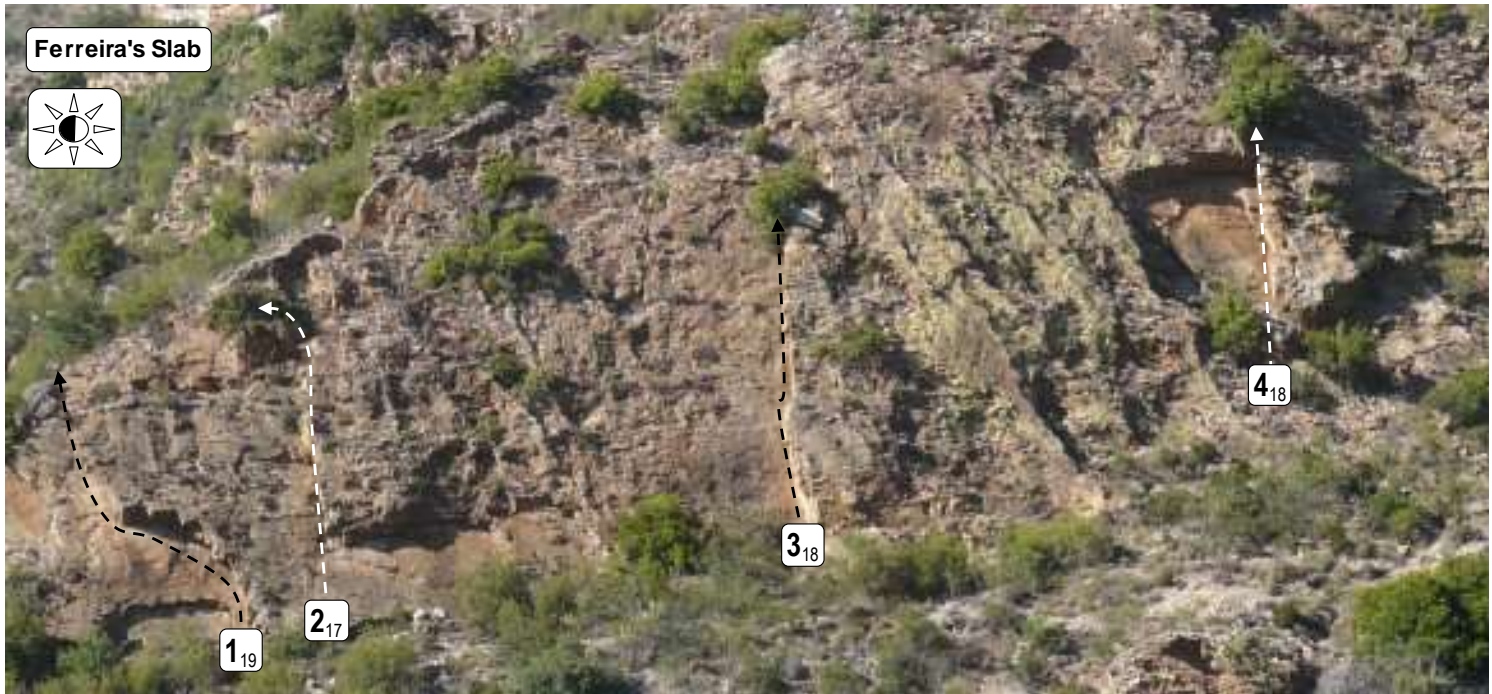

1. Christmas Crescent – 19 ★

Perfect L facing L trending crescent open book.

21m Derek Marshall & Craig Bester 25/12/2005 (T)

2. In the Line of David – 17

Indistinct slab open book. Gear is interesting.

21m Derek Marshall & Craig Bester 25/12/2005 (T)

3. Christmas Crackers – 18 ★

Perfect L facing open book.

19m Derek Marshall & Craig Bester 25/12/2005 (T)

4. Cracker Crackers – 18

L facing open book to abseil tree.

19m Derek Marshall & Craig Bester 25/12/2005 (T)

Invisible Crag



This is the first crag on the path to *Leopard Rock*. It is shaped like a boomerang. All the lines end on a large bomber abseil tree above the highest point. Crag is a bit loose and scary, if you normally only climb sport, consider another crag.

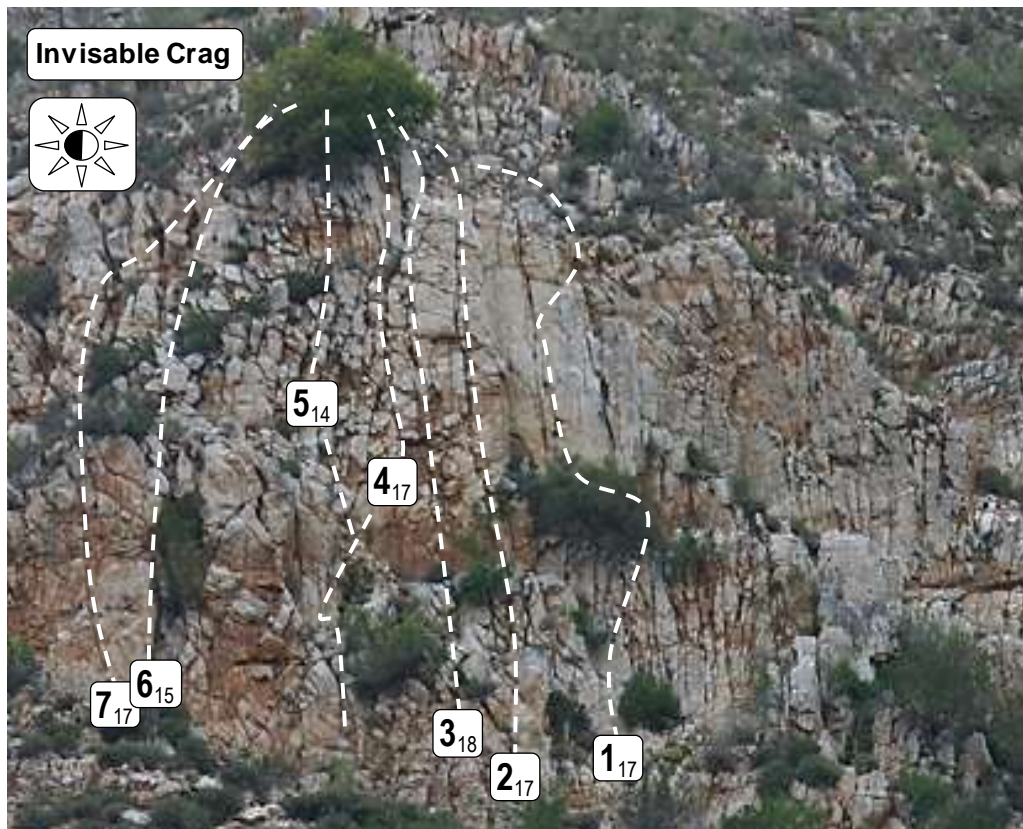

- 1. Societal Collapse – 17** 26m Derek Marshall & Craig Bester 21/12/2005 (T)
3m R of prominent chimney open book, below a small free-standing pinnacle. Up to ledge. Move 2m L, then up prominent crack. 4m up move R onto broken arête. Top out to belay from large tree to the L.
- 2. Violation of the Norm – 17 ★** 25m Derek Marshall & Craig Bester 20/12/2005 (T)
1m L of the arête to the L of the prominent chimney open book. This is the primary line of this crag.
- 3. Shadow of Dreams – 18** 25m Derek Marshall & Craig Bester 20/12/2005 (T)
2m L of *Violation of the Norm*. Crack system that runs R, out of small “roof”. Continue up the arête.
- 4. Polyandry – 17** 25m Derek Marshall & Craig Bester 20/12/2005 (T)
Curving crack 3m L of *Violation of the Norm*. Runs L, out of small “roof”. Moving R onto arête to avoid loose blocks.
- 5. Invisible Green – 14** 25m Derek Marshall & Craig Bester 20/12/2005 (T)
Up steps onto crap ledge. Move up steps to the L. Take the most stable looking line to the large tree.
- 6. Invisible Finger – 15** 27m Craig Bester & Derek Marshall 20/12/2005 (T)
LH & R-facing open book of large recess. Across large ledge. Then find the easiest line to tree.
- 7. Gain & the Gift Given – 17** 28m Derek Marshall & Craig Bester 20/12/2005 (T)
2m L of *Invisible Finger*. Up L curving ‘crack’, onto a ledge. Up easy, broken, dangerous ground. Moving R to tree. As you will see, the “prominent crack” which is visible from the camp site does not exist.

Pinky Purple Wall



Awesome short slab. All the routes are a maximum of about 15m long. This is a sweet place to learn how to trad or refresh your trad legs. Easy 20-minute walk from the campsite. Will have early and late shade in summer. Would be best in mid-morning in winter. Easy walk-off or trees to abseil from.

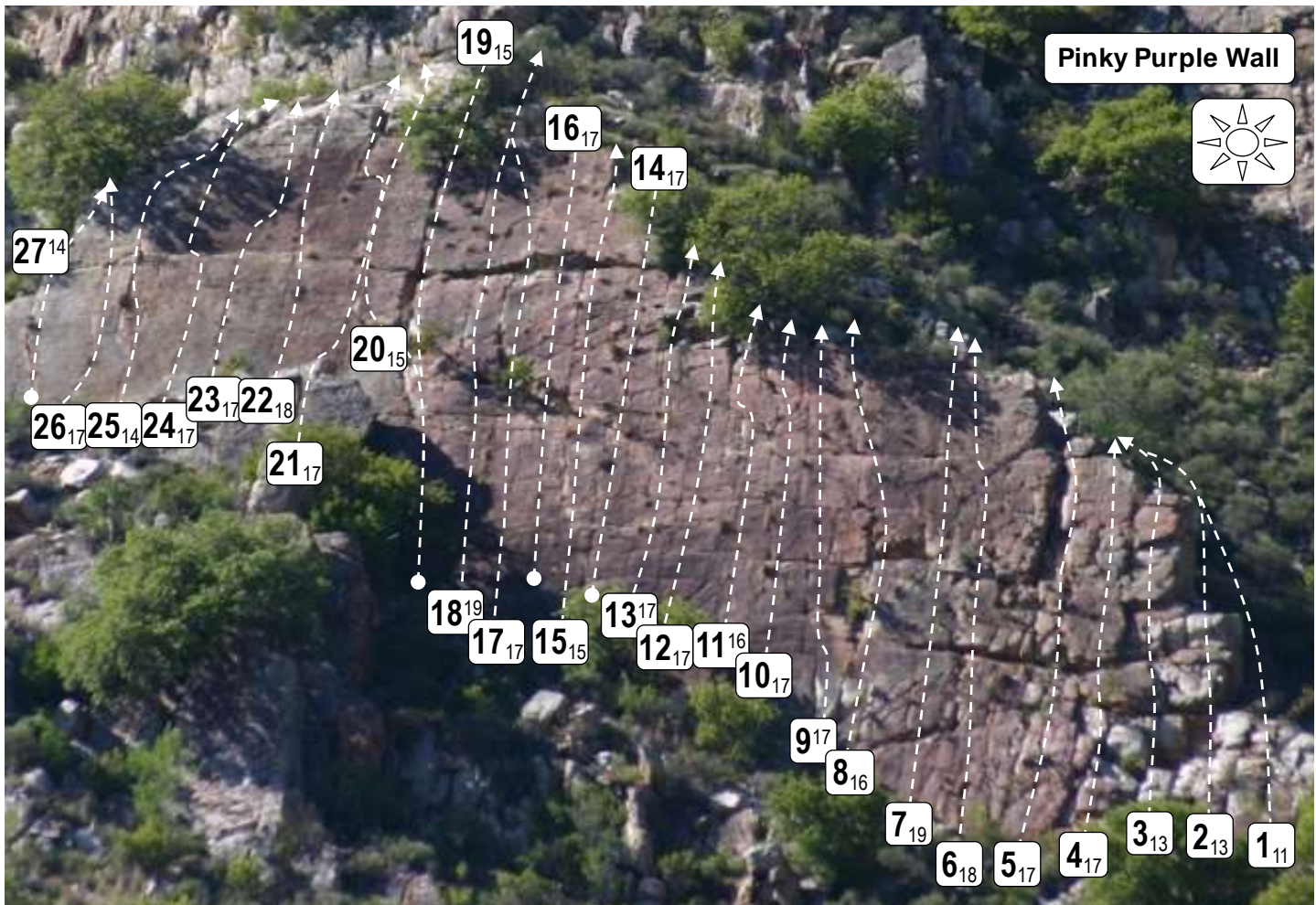

- | | |
|--|--|
| 1. Don't Say a Word – 11 | Craig Bester & Derek Marshall 21/12/2005 (T) |
| Short crack onto first step on the arête. Passed the second step to the top. | |
| 2. Matrix – 13 | Craig Bester & Derek Marshall 24/12/2005 (T) |
| Fist crack onto ledge. Then up jugs & easy ground too second step in the edge. Up the arête to the top. | |
| 3. Whiter Shades of Purple – 13 | Allen Luck & Michael Johnson 16/09/2001 (T) |
| First break from the RH end of the crag. | |
| 4. Divine Aspirations – 17 | Derek Marshall & Craig Bester 21/12/2005 (T) |
| Up the face between the first & second breaks. | |
| 5. 13 Shades of Purple – 17 | Derek Marshall & Allen Luck 16/09/2001 (T) |
| Second break. Becomes a 'V' notch at the top. | |
| 6. Fanta Grape – 18 | Allen Luck & Derek Marshall 16/09/2001 (T) |
| Start 2m L of <i>13 Shades of Purple</i> . From rectangular hole 3m up, trend L. | |
| 7. Purple Pantyhose Eater – 19 | Derek Marshall & Allen Luck 16/09/2001 (T) |
| Start 3m L of <i>13 Shades of Purple</i> . Up hand crack that blanks out 3m up. Continue up blank slab over some horizontal rails. | |



- 8. Dried Apricot Farts – 16** Steven Reed & Lozelle Du Plessis 16/09/2001 (T)
Start at prominent 'V'. Up tiny L facing open book. Up to locked block to L trending zig-zag.
- 9. Pensioner Pink – 17** Derek Marshall & Craig Bester 24/12/2005 (T)
Start 0.5m L of *Dried Apricot Farts*. Follow L trending intermittent crack.
- 10. Tastes Like Purple Chicken – 17** Derek Marshall & Craig Bester 21/12/2005 (T)
Start 2.5m L of *Dried Apricot Farts*. Follow the crack directly above.
- 11. Deep Purple – 16** Vincent & Bronwyn Egan 08/09/2001 (T)
Start 3m L of *Dried Apricot Farts*. Trend L into LH crack.
- 12. Delicious Pink – 17** Derek Marshall & Craig Bester 21/12/2005 (T)
2.5m R of small R facing jagged open book block. Look for a 4-inch R trending diagonal slot. Straight up the thin crack too the top.
- 13. In the Pink – 17** Michael Johnson & Allen Luck 16/09/2001 (T)
1m R of small R facing jagged open book block. Look for an awesome nut placement 2m above ground at the start. Crack improves above.
- 14. Passion for Purple – 17** Bronwyn & Vincent Egan 16/09/2001 (T)
7m R of huge flake. From the top of the block that forms a small R facing jagged open book block. Straight up too a tree on top.
- 15. Protestant Purple – 15** Michael Johnson & Allen Luck 16/09/2001 (T)
5.5m R of huge flake. Up indefinite crack to a slight L trending crack, passed a protruding block near the top.
- 16. Pink Panties – 17** Derek Marshall & Craig Bester 21/12/2005 (T)
4.5m R of huge flake. Up thin line with poor gear too a ledge. Continue up through middle of ledge.
- 17. Purple Beret – 17** Derek Marshall & Allen Luck 16/09/2001 (T)
3m R of huge flake. Up twin thin cracks. Move R into broken cracks.
- 18. Purple Pelican – 19** Derek Marshall & Allen Luck 16/09/2001 (T)
1m R of huge flake.
Start at the same point as *Y2 the Left*, but keep directly up.
- 19 Y2 the Right – 15** Allen Luck & Derek Marshall 16/09/2001 (T)
1m R of huge flake.
Start at the same point as *Y2 the Left*, move somewhat L into an off-width.
- 20. Y2 the Left – 15** Allen Luck & Michael Johnson 16/09/2001 (T)
1m R of huge flake. Move far L at hollow, into hand crack.
- 21. Purple Turtle - 17** Derek Marshall & Allen Luck 16/09/2001 (T)
Up off-width between large flakes, then into same crack as *Y2 the Left*.
- 22. Wild Cherry – 18** Michael Johnson & Allen Luck 16/09/2001 (T)
Start just L of huge flake. Straight up.
- 23. Sweet Temptation – 17** Derek Marshall & Craig Bester 21/12/2005 (T)
2.5m R of *Purple Heart*. Intermittent finger crack, that starts off cube. Crack ends on rail. Move 0.5m R into short finger crack.
Run for the top.
- 24. Pink Desires – 17** Derek Marshall & Craig Bester 21/12/2005 (T)
1.5m R of *Purple Heart*. Start in light crack. Straight up moving 0.5m L into short finger crack.
- 25. Purple Heart – 14** Allen Luck & Derek Marshall 16/09/2001 (T)
Dead straight finger crack. Move L into short curving off-width.
- 26. Rocket Ride – 17** Derek Marshall & Craig Bester 21/12/2005 (T)
Start in thin crack 1m L of *Purple Heart*. Crack steps slightly L twice.
- 27. Angry Purple Worm – 14** Craig Bester & Derek Marshall 21/12/2005 (T)
Short finger crack that runs into arête. Stay R of arête.

Vinland



Vinland is to the L of *Leopard Rock*. The routes are of a reasonable length & the rock is stable.

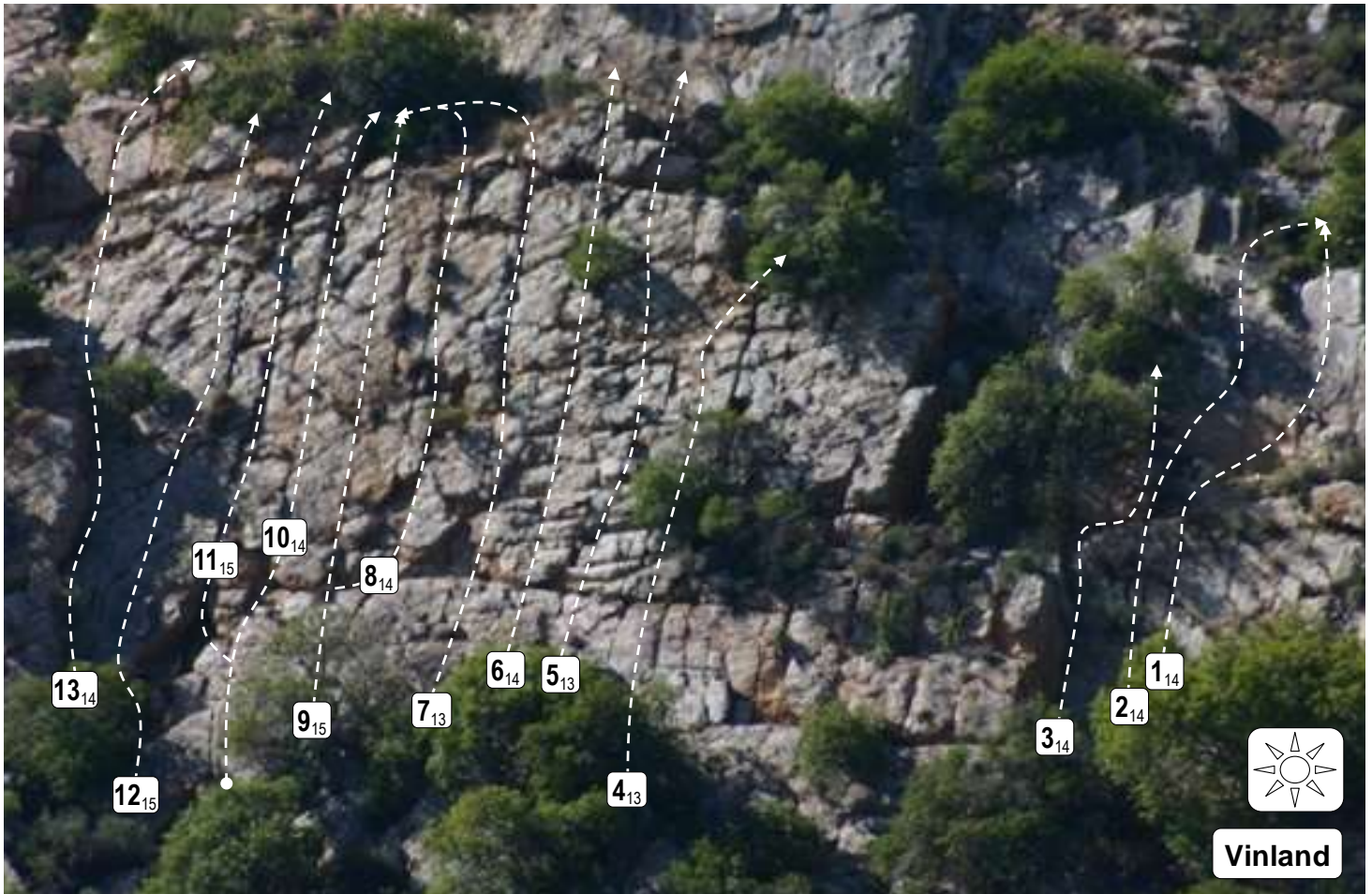

- 1. Freedom & Fortune – 14** 15m Derek Marshall & Craig Bester 23/12/2005 (T)
Crack to the R of off-width open book. Across ledge, up crack L of the arête. Belay at good abseil tree.
- 2. Pinky & the Brain – 14** 15m Craig Bester & Derek Marshall 23/12/2005 (T)
Crack between off-width open book & finger crack. Up moving R across ledge to tree belay.
- 3. The Lonely Road of Fear – 14** 15m Craig Bester & Derek Marshall 23/12/2005 (T)
Up off-width open book. Move R & up.
- 4. This is My Energy – 13** 23m Craig Bester & Derek Marshall 23/12/2005 (T)
Start up easy blank slab. Past some trees, staying L of off-width. Then move R to tree on a ledge.
- 5. Silent Dream – 13** 25m Derek Marshall & Craig Bester 24/12/2005 (T)
Start up easy slab that starts below the majority of the crag & becomes a pillar. Up easy crack system slightly R of the pillar.
- 6. Warriors of the Faith – 14** 25m Derek Marshall & Craig Bester 24/12/2005 (T)
Start up easy slab that starts below the majority of the crag & becomes a pillar. Then up lovely easy crack to the top.
- 7. Legacy of Kings – 13** 19m Derek Marshall & Craig Bester 23/12/2005 (T)
6.5m R of inverted 'V' roof. From the first ledge, move R into easy crack.
- 8. Breaking the Law – 14** 18m Derek Marshall & Craig Bester 23/12/2005 (T)
4.5m R of inverted 'V' roof. Up finger crack with a few grass clumps.
- 9. Steel Meets Steel – 15** 17m Derek Marshall & Craig Bester 23/12/2005 (T)



2.5m R of inverted 'V' roof. Up seemingly blank face. Pro becomes a concern.

10. Forces of Steel – 14 23m Derek Marshall & Craig Bester 23/12/2005 (T)

1.5m R of inverted 'V' roof. Up past triangular block that forms a small roof. Straight up to notch at the top.

11. Turning Meadows into Graves – 15 19m Derek Marshall & Craig Bester 23/12/2005 (T)

Up hand crack above inverted 'V' roof. Moving R into recess. Straight up.

12. Winter Waiting – 15 18m Derek Marshall & Craig Bester 23/12/2005 (T)

1.5m L of inverted 'V' roof. Up seemingly blank face.

13. New Found Land – 14 18m Derek Marshall & Craig Bester 24/12/2005 (T)

Off width R facing open book. Up crack above.

Leopard Rock



Leopard Rock is the prominent smooth wall set high above the campsite. This is where it all started at Kouga Wildernis. This area was pioneered by Vincent & Bronwyn Eagan in 2001. Walk-in is on a good path made by the farmer & his men. They did a really good job

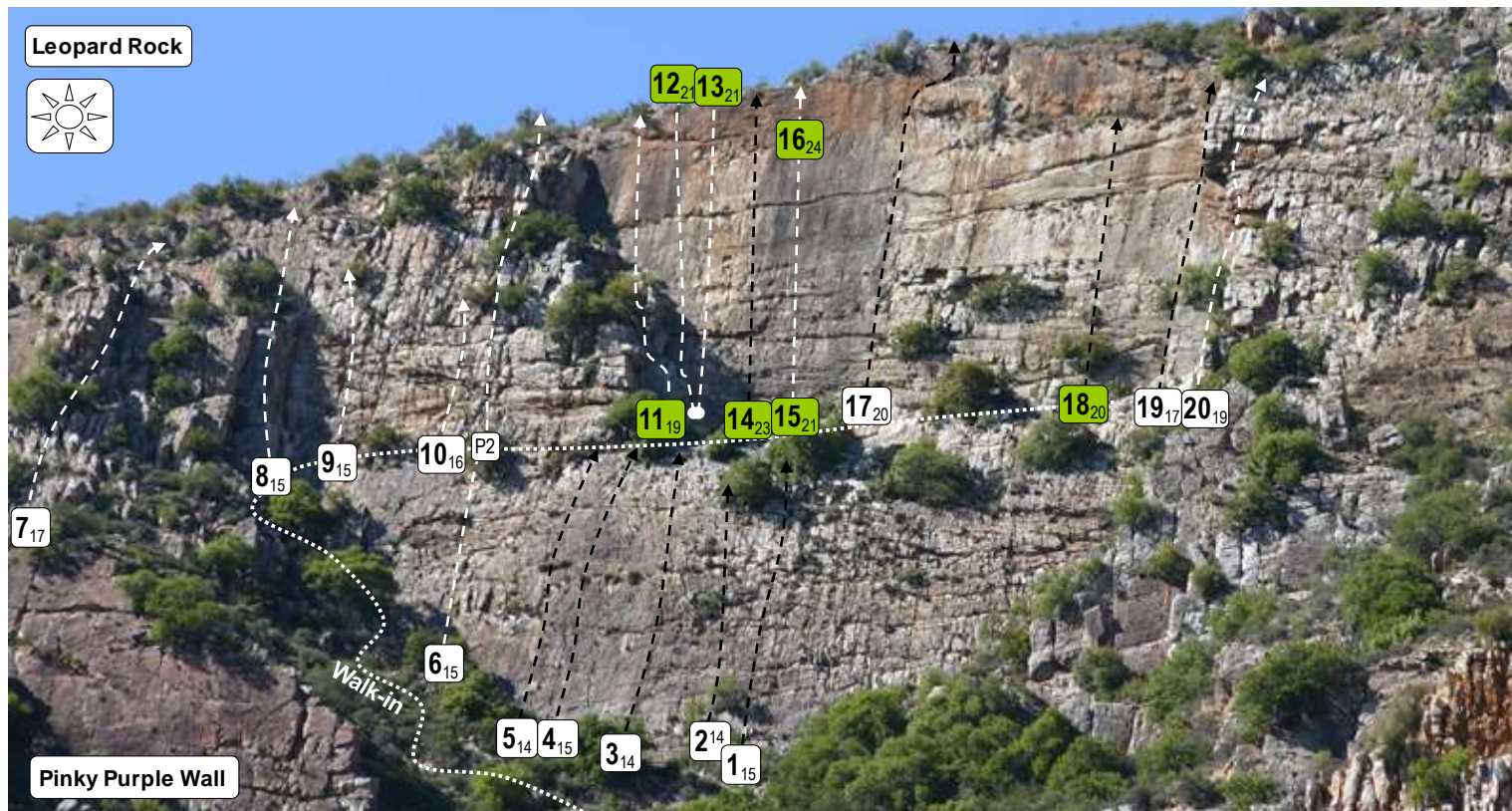

- | | |
|---|--|
| <p>1. Shadowman – 15
Easy trad crack up slab to good tree abseil.</p> <p>2. Zwartkopsicht – 14
Easy trad slab to tree abseil.</p> <p>3. Meadowlands – 14
Follow the line directly below the bolted line <i>Ingwe</i>.</p> <p>4. Aloe Aloe – 15
Similar to <i>Walk in the Park</i>, this route follows a diagonal line, trending R & ends at the base of the bolted line <i>Ingwe</i>.</p> <p>5. Walk in the Park – 14
Up thin vertical cracks on slab face, abseil off tree or walk-off L on ledge.</p> <p>6. I Have not Bin Laden Today – 15
P1 Up slab face to assess ledge.
P2 continues all the way to the top.</p> <p>7. House of Cards – 17
Loose & chossy. Avoid!</p> <p>8. Wildlife – 15
Start up R facing open book.</p> <p>9. Striatablasta – 15</p> | <p>Bronwyn & Vincent Eagan 06/10/2001 (T)</p> <p>Lozelle Du Plessis & Steven Reed 09/09/2001 (T)</p> <p>Vincent & Bronwyn Eagan 08/09/2001 (T)</p> <p>Steven Reed & Lozelle Du Plessis 08/09/2001 (T)</p> <p>Bronwyn & Vincent Eagan 16/09/2001 (T)</p> <p>Lizanne & Bill Tucker 16/09/2001 (T)</p> <p>Vincent & Bronwyn Eagan 06/09/2001 (T)</p> <p>Matt Tranter & Vincent Eagan 30/09/2001 (T)</p> <p>Vincent & Bronwyn Eagan 08/09/2001 (T)</p> |
|---|--|



Easy slab trad with no surprises.

10. Blockout – 16

Bronwyn & Vincent Eagan 06/10/2001 (T)

Easy indistinct pleasant line.

● **11. Dom Kraag – 19 ★**

Martin Rehm & Derek Marshall 06/01/2008 (9B&C)

Bolted by Morne van der Mescht.

● **12. Operation Indwe – 21 ★★**

Derek Marshall & Terence Trevaskis 22/10/2011 (T)

Start at the same place as *Ingwe*. Up diagonally L, then straight up to the thin crack 2m L of the chains for *Ingwe*. Gear is limited.

● **13. Ingwe – 21 ★★★**

Vincent & Bronwyn Eagan 16/09/2001 (11B&C)

● **14. Resistance – 23 ★★**

Derek Marshall & Terence Trevaskis 22/10/2011 (12B&C)

Bolted by Juan-dray Marshall.

● **15. Ripped & Torn – 21 ★★★**

Derek Marshall & Terence Trevaskis 23/10/2011 (12B&C)

● **16. Unholy Terror – 24 ★★★**

Juan-dray & Derek Marshall 28/01.2012 (12B&C)

Extension above *Ripped & Torn*.

17. Protection Racket – 20

Patrick Fraser & Karen Bedford 27/12/2006 (T)

In the middle of the face up the obvious break, moving R near the top. Not much gear!

● **18. One Two One Zulu – 20 ★★**

Derek Marshall & Allen Luck 16/09/2001 (12B&C)

19. Purple Rage – 17 ★★

Derek Marshall & Allen Luck 15/09/2001 (T)

Prominent open book on the RH side of the face.

20. Helter Swelter – 19

Bronwyn & Vincent Eagan 30/09/2001 (T)

Up the slab R of the Purple Rage open book, up a L of first roof. Up the open book to the next roof then up the arête.

Rain Maker



These very easy routes are on the R of the lower wall of Leopard Rock.

- | | |
|--|--|
| 1. !kwerri-/nan – 14 | 15m Derek Marshall & Craig Bester 24/12/2005 (T) |
| Up the awesome crack just R of a stack of huge blocks that forms an off-width. This crack is not visible from below & is set in a recess between two open books. | |
| 2. Rain Makers – 13 | 15m Derek Marshall & Craig Bester 24/12/2005 (T) |
| Up the arête to the L of an easy slab. | |
| 3. Children of the Rain – 13 | 15m Craig Bester & Derek Marshall 24/12/2005 (T) |
| Up middle of easy slab. | |
| 4. Water Snakes – 13 | 18m Craig Bester & Derek Marshall 24/12/2005 (T) |
| Prominent open book. | |
| 5. Santa Watches Granny Porn – 13 | 16m Craig Bester & Derek Marshall 24/12/2005 (T) |
| Up arête to the R of <i>Water Snakes</i> , move R to an abseil tree. | |
| 6. Pensioner Passion – 7.5 | 16m Craig Bester & Derek Marshall 24/12/2005 (T) |
| Very easy crack, totally awesome at the grade. | |
| 7. Wailing Granny – 7.6 | 16m Craig Bester & Derek Marshall 24/12/2005 (T) |
| 1.5m R of <i>Pensioner Passion</i> . Also, very easy. | |
| 8. Bleddy Boy – 10 | 15m Craig Bester & Derek Marshall 24/12/2005 (T) |
| 3m R of <i>Pensioner Passion</i> . Up LH edge of slab. | |
| 9. Bleedie Boy – 10 | 15m Craig Bester & Derek Marshall 24/12/2005 (T) |
| Up middle of slab. | |

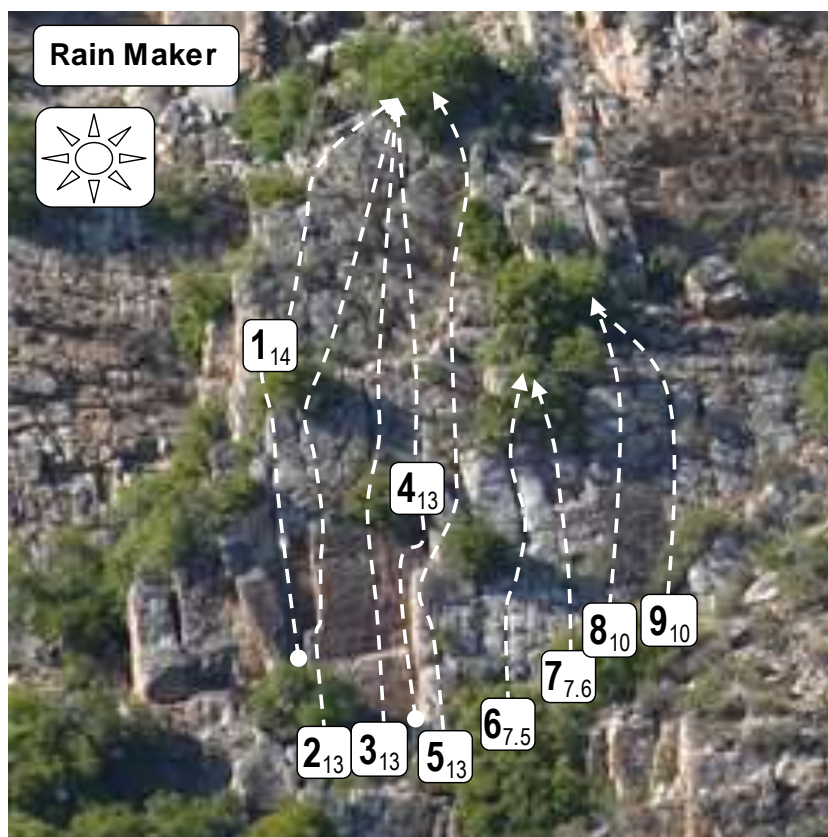

Heuning Kranz



Follow the track that leads up the kloof from the field below the main campsite. The track ends at what is known as a wilderness campsite. This campsite is actually quite civilized, good camping with flush toilet & hot showers, but manages to keep it's remote unspoiled setting. There is plenty of shade in summer & an awesome natural swimming spot.

The following routes are on a small face just before crossing the stream to the camping. Walk-in is 70m max on flat ground. Routes are recorded R to L.

- **1. End of the Rainbow – 21 ★** Derek Marshall & William Lesley 07.01.2012 (6B&C)
- **2. Enemy Within – 22 ★** Derek Marshall & William Lesley 07.01.2012 (6B&C)
- **3. Final Attack – 17** Derek Marshall & William Lesley 08.01.2012 (6B&C)
- **4. Veiled Evil – 15** Derek Marshall & William Lesley 08.01.2012 (6B&C)
- **5. Racoom – 18 ★** Terrance Trevaskis & Derek Marshall 28.01.2012 (6B&C)

The following route is above & R of the small face.

- **6. The Toyota Way – 20 ★** Derek & Juan-dray Marshall 02.03.2014 (12B&C)

On the fins to the L of the cave in the campsite.

7. Sliding Doors – 14

Derek Marshall & William Lesley
06.01.2012 (T)

Up the LH side of the fin, onto a ledge.
Continue up to the top.

8. Higher Ground – 17

Derek Marshall & William Lesley
06.01.2012 (6B&C)

Up the R facing open book. Through the roves, stay on the RH fin. Move L to a ledge to with a good tree to abseil from.

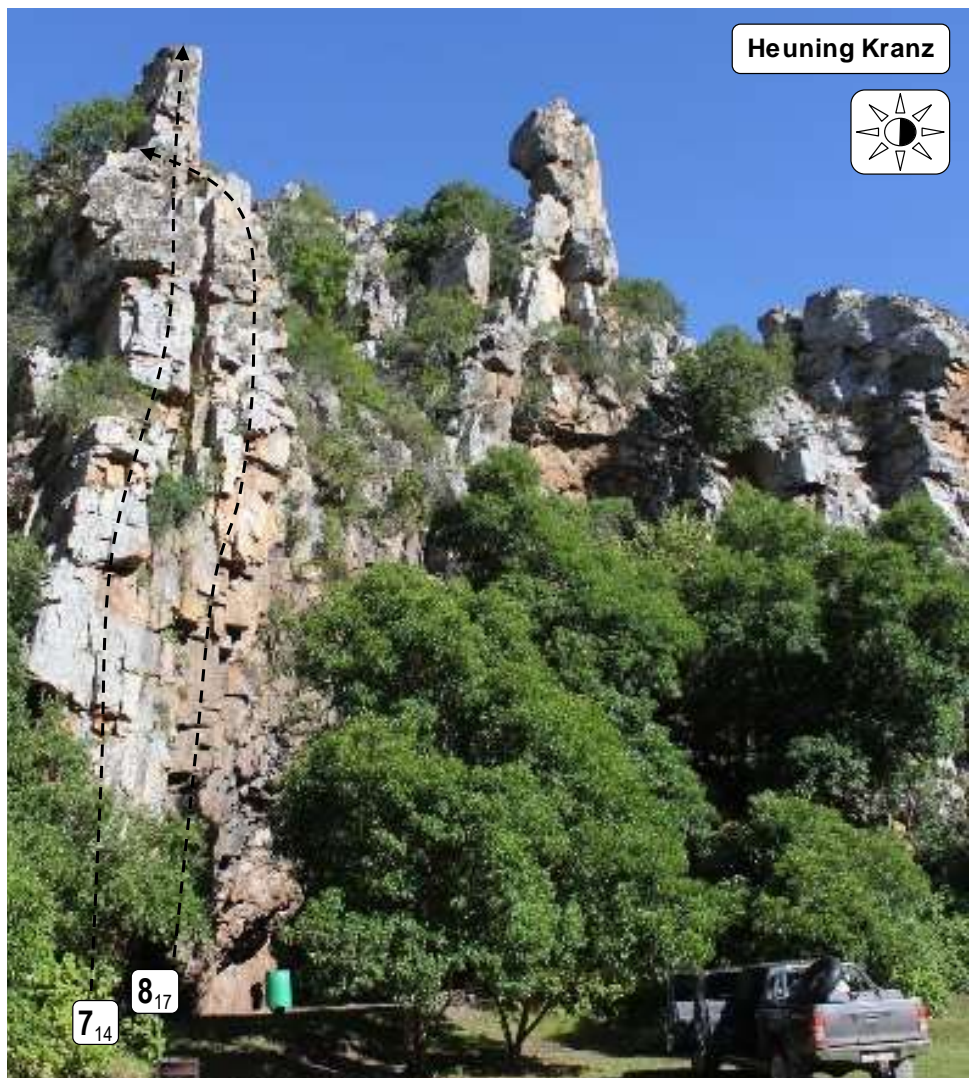



In the cave in the campsite.

- 9. *Open Project – 27-ish*
- 10. *Open Project – 27-ish*
- 11. *Open Project – 26-ish*
- 12. *Let it Roar – 21*
- 13. *Hate to Love Me – 17*

(5B&C) Juan-drax Marshall

(5B&C) Juan-drax Marshall

(4B&C) Juan-drax Marshall

Juan-drax & Derek Marshall 28.01.2012 (5B&C)

Juan-drax Marshall & Robyn Bonnette 28.01.2012 (T)

Easy crack to R.

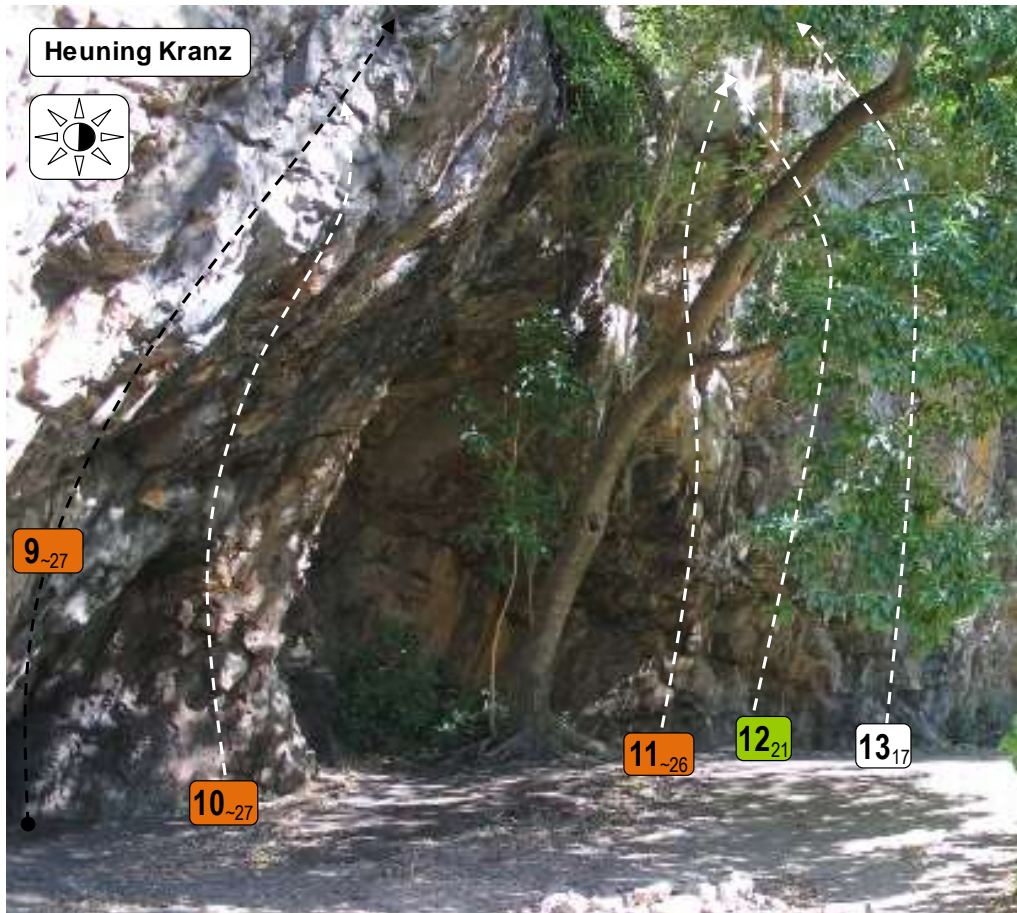

Koos sê Bos



Follow the path from behind the main cottage & over the spur. It is a long walk, especially if it is hot. Take water & a hat. The path is very good. The path moves from dry scrub into a lush kloof, this is Koos Sê Bos.

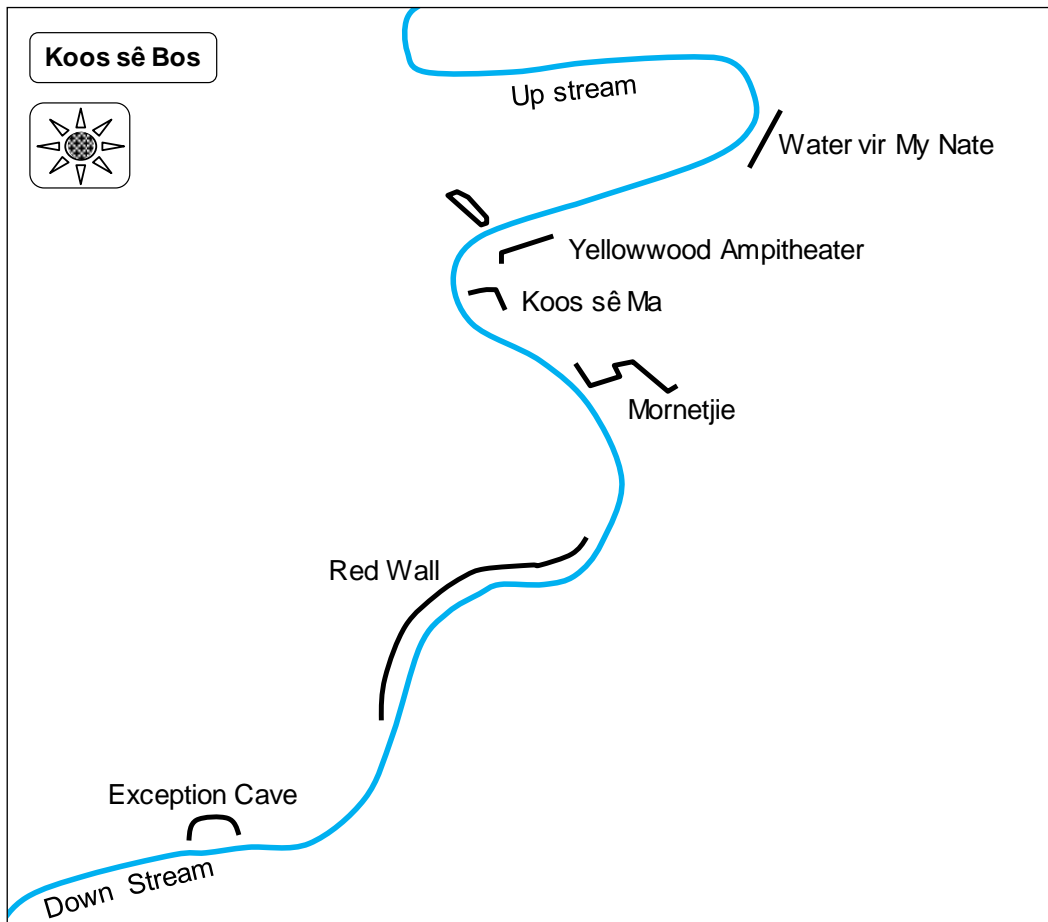

Exception Cave



This is a prominent cave on the LH side of the stream if you are facing up stream. The farmer has allowed climbers to hike in & sleep in the cave. This is a fair option. There are Bushman paintings, artifacts & even human teeth in the cave. Please avoid scratching in the cave & note that it is illegal.

Routes are recorded downstream to up stream.

1. Eager Egans – 18

Bronwyn & Vincent Eagan 11/09/2003 (T&C)

P1 Start 3m L of LH arête of cave. Up a tiny R trending open book. Up a straight break to below a roof.

P2 Move R into gully break & up to some chains.

2. A Place We Call the Zoo – 19

Vincent & Bronwyn Eagan 11/09/2003 (T&C)

P1 1m L of the LH arête of the cave, up crack, moving L to below a roof.

P2 Move back R into gully break & up to some chains.

3. Except Morné – 24 ★★

Morné van der Mescht & Vincent Eagan 11/09/2003 (T&C)

4m L of Bushman hand print, up parallel cracks. Through the easiest looking break in the roof.

4. Break Dance – 24 ★★

Morné van der Mescht & Vincent Eagan 19/01/2003 (T&C)

2m R of Bushman hand print, up prominent break, just L of the arête. Funny pockets to an old tree on a ledge.

5. Taking a Dump – 18

Derek Marshall & Bill Tucker 17/09/2001 (T)

Just outside the cave on the upstream side.

P1 Up R facing off-width open book. Move 1m L onto open book below the roof. Through the roof to a belay ledge.

P2 Easy scramble to the top. Move down stream to find the abseil chains of *Eager Egans*.

6. Accept Us – 15

Dricus Bezuidenhout, Magnus & Viera Wagener 30/12/2005 (T)

P1 – 15 On the small buttress R large yellowwood.

P2 -14 Across some grassy slopes up small L facing open book on the RH side of small buttress. Move up a series of stepped open books.

Red Wall



175m upstream of the cave, the *Red Wall* is prominent.

1. Heaven & Hell – 20

Morné van der Mescht, Vincent & Bronwyn Eagan 26/01/2003 (T)

P1 - 19 - 25m Prominent layback crack, start just L of base of prominent nose. Up to a tree on the bridge of the nose.

P2 – 17 - 20m From the bridge of the nose, keep on up to base of open book.

P3 – 20 - 25m Up the open book to a large ledge.

P4 – 14 - 30m Scramble up easy flakes to belay spot on top.

Walk off in downstream direction.

2. Surrender or Die – 18

Dricus Bezuidenhout & Magnus Wagener 30/12/2005 (T)

P1 – 18 - 9m R of nose & just R of prominent red open book before the face gets steep. Up jutting block that bridges roof, moving L to trees. Then up short square groove & R onto large square ledge.

P2 – 16 From large square ledge move L onto front of small protrusion. Up crack in the middle of protrusion, not a large square ledge with large block. Abseil from this block.

3. Invasion – 17 ★

Derek Marshall & Hubertus Hoelzmann 30/12/2005 (T)

P1 – 14 - 12m Same start as *Surrender or Die*. Move R into R facing open book. Move further R onto a ledge under the steep part.

P2 – 15 - 12m Traverse L & up through the open book, onto the same square ledge as P2 of *Surrender or Die*.

P3 – 17 31m From the square ledge, up RH R facing open book. Traverse trending up & R over a series of square roves to a point where the roves diminish, below a short L facing open book.

P4 – 16 34m Traverse 4m L under roves into a square groove to a fricking crap ledge. Move L into R facing open book. Top out & scramble/walk 150m upstream on a spur.

Cute Crag

Very short routes on a small crag on the LH side of the stream, just past the *Red Wall*.

1. Like - 12

Just L of LH arête.

Craig Bester & Jessica Jeffries 30/12/2005 (T)

2. Yummy – 14

Jagged line L of nose.

Craig Bester & Jessica Jeffries 30/12/2005 (T)

3. Snow White – 15

Prominent R facing open book.

Craig Bester & Jessica Jeffries 30/12/2005 (T)

4. Creamy – 16

Craig Bester & Jessica Jeffries 30/12/2005 (T)

1.5m R of prominent R facing open book.

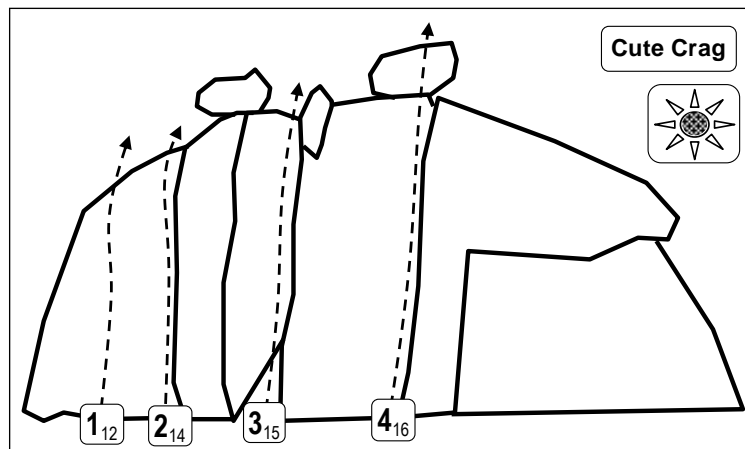

Mornetjie



This is a very small crag on the RH side of the stream. The front face drops into the stream.

1. The Morne – 16

Morné van der Mescht & Craig Bester 30/12/2005 (T)

R facing open book to L of chimney.

2. Lekker Dik Gat – 14

Craig Bester & Morné van der Mescht 30/12/2005 (T)

Prominent chimney.

3. Sweetness – 15

Craig Bester & Morné van der Mescht 30/12/2005 (T)

L facing wide open book. R of prominent chimney.

4. Cool-erigga – 16

Morné van der Mescht & Craig Bester 30/12/2005 (T)

Up R trending, R facing overhanging open book.

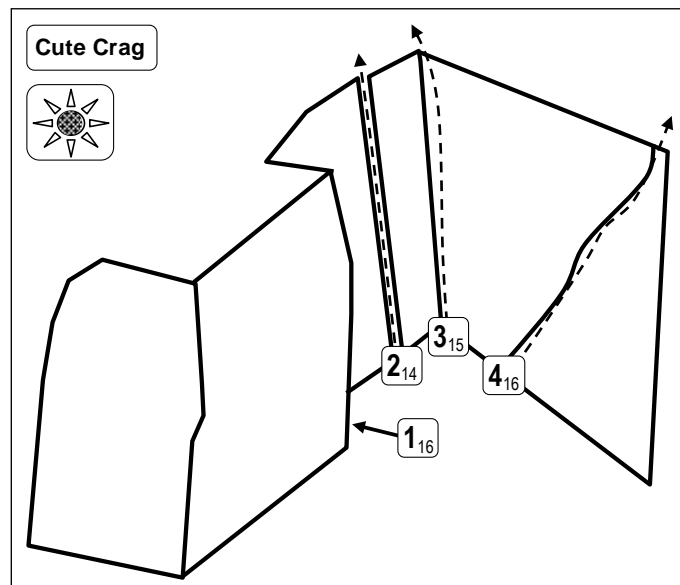

Koos Sê Ma

Tiny crag 60m upstream of *Mornetjie*.

1. Lekker Ding – 17

Michael & Monique Lemmer 30/12/2005 (T)

Prominent line on a slab face that juts out to the stream on the RH side of the stream. 6m R of blunt jagged arête. Up prominent hand crack through roves 4m up. Continue up till trees.

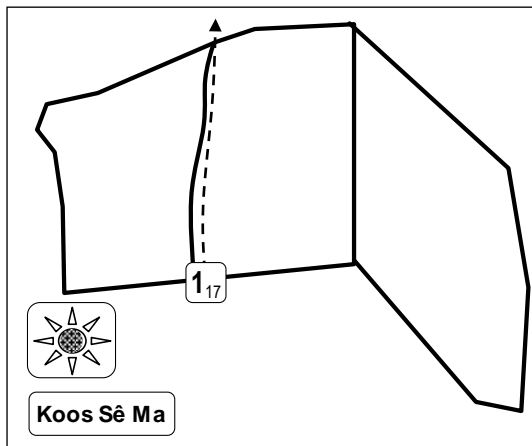

Yellowwood Amphitheatre



Opposite a short pinnacle on the RH side of the stream. The crag starts with an overhang & remains overhanging. Small Bushman paintings near the beginning.

1. New Age Bushmen – 18

Morné van der Mescht & Jessica Jeffries 30/12/2005 (T)

Start up a L curving overhanging hand & fist crack.

2. I Knew a Bushman – 17

Morné van der Mescht & Jessica Jeffries 30/12/2005 (T)

On upstream side of pinnacle up two open books on top of each other. Up to the base of the pinnacle.

These routes are some where close to the pinnacle on the upstream side.

3. Gone Fishing – 15

15m Michael & Monique Lemmer 30/12/2005 (T)

Upstream side of the pinnacle.

4. Should have Wanked Off – 18

28m Michael & Monique Lemmer 30/12/2005 (T)

Upstream of the pinnacle. Not a wonderful line.

Water vir My Nate

From the cave keep going up stream. 15 minutes past the first pinnacle at the first grassy clearing, just past a huge yellowwood. On the RH side on a jutting semi-free-standing protrusion.

P1 – 18 On the lower portion of the downstream face, climb the straight finger crack. Two thirds the way up the face, traverse R into prominent open book. Up this & R to a good belay ledge.

P2 – A0 Traverse L under a block, through a cubby & onto a ledge. Up a short easy section.

Abseil down to a walk-off on the upstream side of the semi-free-stander.

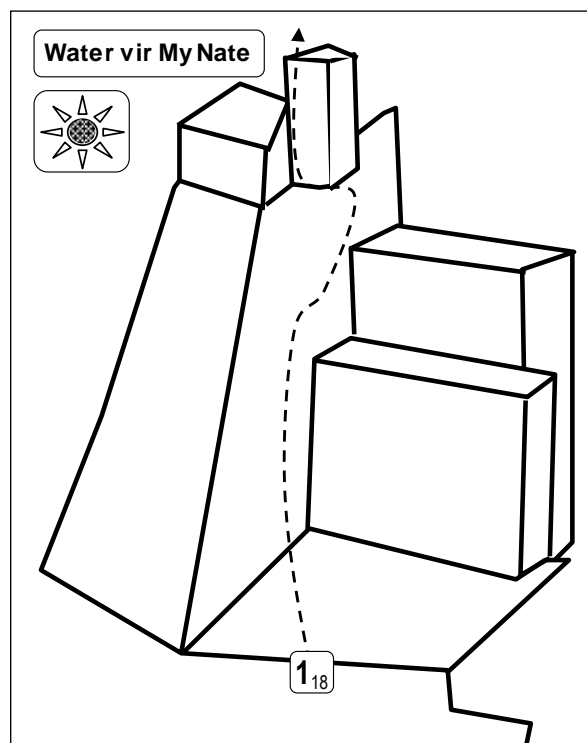

Skrikrivier



Directions: From the R62 turn onto the gravel road to Onder-Kouga. Follow this road to a fork, take the RH option. Over the rugged mountain pass & cross the Kouga River. In the valley find a modern farmhouse on the L. Immediately before this farmhouse is a gate & a bouldery track follow this for 2km to an abandoned farmstead. Park. Walk back to the river. Walk upstream for about 45 minutes till the path is blocked by a deep crystal pool, between two ribs of rock.

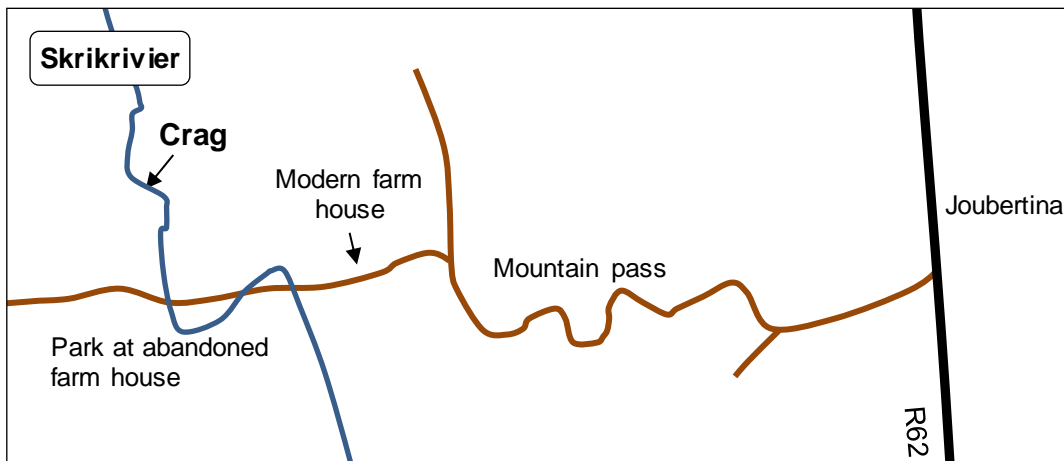

1. Golgotha – 16

Gavin Stewart, Michael Craig & Don MacLennan 21/04/1984 (T)

P1 – 10 - 15m Take the easiest line from the water's edge to the platform. Walk to the vertical rib.

P2 – 16 - 25m Climb the recess L of the rib, up then R, climb the front of the rib to a ledge with a bush.

P3 – 10 - 20m Traverse R using the obvious ledge for hands. Near the corner the ledge is very loose. Up the corner with trees.

A more direct 3rd pitch begs to be done & there is a stuck friend in the middle of the 2nd pitch.

